



Innovative Sheet Metal Forming Technologies

www.skpmakina.com.tr

From 1998 to present...

SKP Makina ve Kalıp,

Which started its operations in a small workshop in 1998 have strived to continue providing the best service to its clients while also continuing its development on a closed area of 7,000 m² on 10,000 m² of land in Manisa Organized Industrial Site.



10.000 m² Area



7.000 m² Closed Area

New Factory Investment (2020)



SKP 2nd factory project to be completed in year 2024



SKP 2nd factory construction to be completed in year 2024



Our Vision

Parallel to the technological developments in 2028 focused on the added value products, having renewed itself with a proactive approach and having obtained the **ISO 500** certificate becoming an export company for customers on **5 continents** that aims for shared purposes.

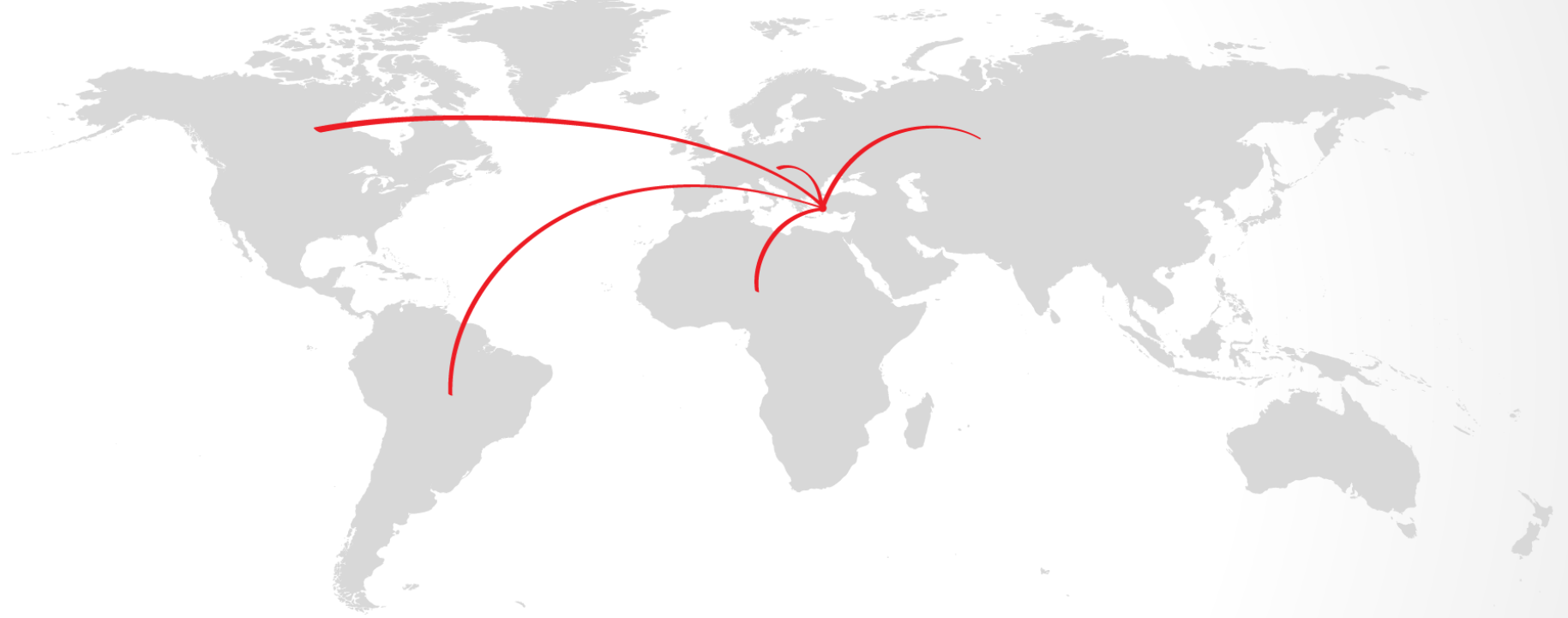

Our Mission

Cooperating for appropriate production in terms of forming and combining mould and sheet metal parts with metal by using the developing technologies for global automotive, heating-cooling and white goods companies.

Within this context, our aim is to satisfy all of our domestic and foreign customers as well as to contribute to the society and to our country's economy.





Design Center

Turkey needs to make rapid progress in R&D, design, innovation and branding in order to achieve the highest level in technology. This only seems possible through the improvement of the quality of education and investment; and the development of R&D, Innovation, Design and Branding: the 4 components of High Added Value.

Our purpose is;

- to ensure and encourage technological knowledge,
- innovation in the product and in the production processes,
- improvement of the quality and the standards of the product,
- commercialization of technological knowledge,
- and to increase the employment of designers and qualified workers.



Training Academy

Our purpose is;

- With the apprenticeship training system, to provide important contributions to our country which is in a rapid industrialization process, a quick, economic and active solution to the employment of qualified intermediate manpower,
- to increase production quality and capacity with our apprentices through a theoretical training,
- to prevent apprentices from changing their workplaces randomly and to bring a work discipline to their carriers by signing a contract before the training,
- to enable industrial high school students to demonstrate their skills in a real business environments,
- On this path we have set out to be one of the leading companies of the industry with our products we export to 5 continents worldwide, our special production metal-shaping tools, and our dynamic employees; we are taking firm steps by turning our face to developments and leaning our back to our values, without compromising quality and by learning from our mistakes, while also considering the current needs and expectations of the industry.



Quality

- **ISO 9001 : 2000** Quality Management System Certificate Received **in 2003.**
- **ISO/TS 16949 : 2009** Quality Management System Certificate Received **in 2013.**
- **IATF 16949 : 2016** and **ISO 9001 : 2015** are updated as of **in 2018.**
- **ISO 3834** Based Manufacturing Adequacy Management System **in 2021.**
- **ISO 45001** Safety Management Certificates **in 2021.**
- **ISO 14001** Environmental Management System **in 2021.**



Tool & Die Shop - Machine Equipments

Machine	Dimensions	Quantity
EDM – Wire	800 x 600 mm	1
EDM – Wire	600 x 400 mm	1
EDM	500 x 300 mm	1
EDM - Drilling	400 x 200 mm	1
CNC Double Column Machining Center	3150 x 2040 x 780 mm	1
CNC Vertical Machining Center	1600 x 800 x 750 mm	1
CNC Machining Center	1000 x 500 x 500 mm	1
Surface Grinding	1600 x 500 mm	1
Surface Grinding	600 x 400 mm	1
Lathing Machine	Ø500 x 1500 mm	1
Milling Machine (Universal- NC)	1200 x 400 mm	3
Hardness Tester		1
CMM (DEA) 3D Measurement Tool	2000 x 1000 x 700 mm	1
Crane (10t)		2
Crane (5t)		2



Press - Machine Equipments



Machine	Quantity
Eccentric Press (300 - 800 t) H type	7
Eccentric Press (60 - 150 t) C type	11
Hydraulic Press (300 t) H type	3
Hydraulic Press (100 - 250 t) c type	3
Compact Roll feeder (max. 800 mm)	3
Roll feeder (max. 400 mm)	4
Transfer System	1

Flexible Manufacturing Equipments

Makina	Ölçü	Adet
Laser Cutting Machine	800x600 mm	1
Fiber Laser Cutting Machine	600x400 mm	1
5D Laser Cutting Machine	2750 x 1250 mm	1
Panel Bender	3150 x 2040 x 780mm	3
Punch	500x300 mm	1
CNC Press Brake	400x200 mm	4
Spot Welding Machine (With Current Adjustable Unit)	1600 x 800 x 750 mm	7
TIG – MIG - MAG Welding Machine	1600 x 500 mm	9

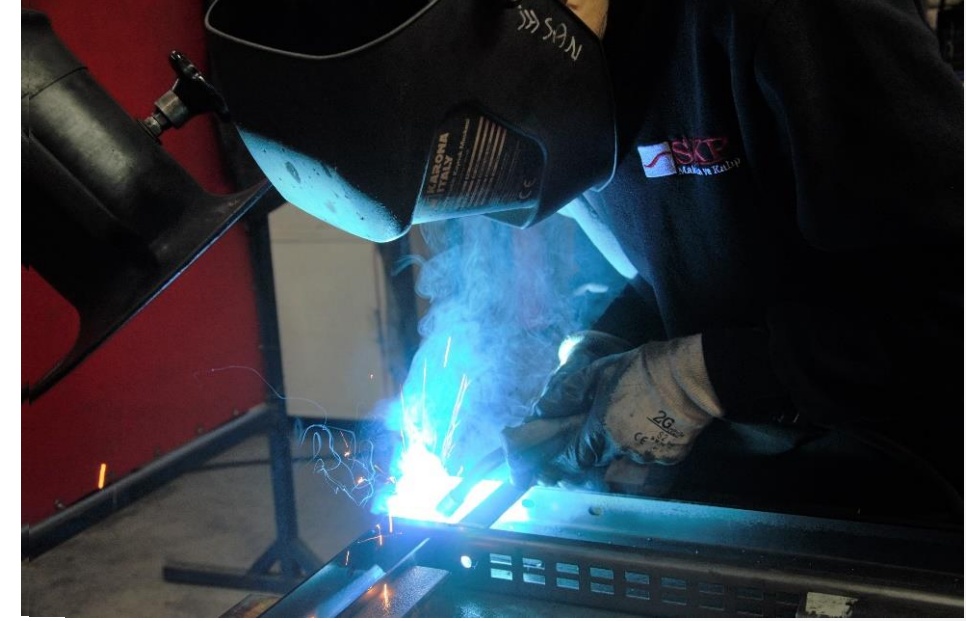

(03/2024)

1 Piece 800 Tons Ales Press Investment



(01/2024)

1 Piece 300 ve 1 Piece 400 Tons Simpac Press Investment



Design Office

In our experienced and well- equipped design office, parts and patterns turn from abstract into concrete. We offer design solutions to create customized products for our customers.

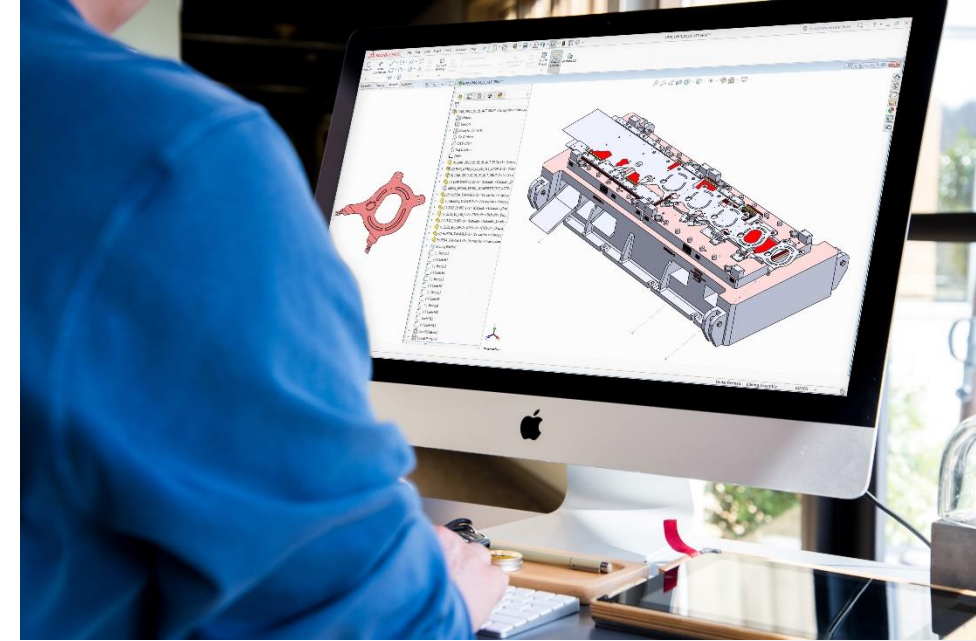

References in Turkey

VIESSMANN
TÜRKİYE

emas
E.C.A.®

DemirDöküm
Vaillant

arçelik

FRANKE

VESTEL

BOSCH

AKG

MM
PACKAGING

UĞUR

KLİMASAN

Metalfrío

GROUPE ATLANTIC
THERMAL COMFORT FOR ALL
atlantic lazzarini Thermore Jauter

vileda
a brand of
FREUDENBERG

MITSUBISHI ELECTRIC

Ege Fren

COŞKUNÖZ
METAL FORM

BMC

FAZ
ELEKTRİK

Volt elektrik motorları

MAXION İNCİ

SAFKAR

Export References

ALLGAIER
Allgaier-Group

artel

VIESMANN



AKG



ebmpapst

WESTFALIA
Seat Parts



MAXION
WHEELS



martin
Stanz- und Umformtechnik

HMT
HELDENER METALL TECHNIK

ERXLEBEN
VERFORMUNGSTECHNIK

EMERSON



Integral
Stanzan - Prägen - Abkanten - Schweißen

Steel
METAL IN FORM

KONIG METALL

TUYAUTO
EQUIPEMENTIER AUTOMOBILE

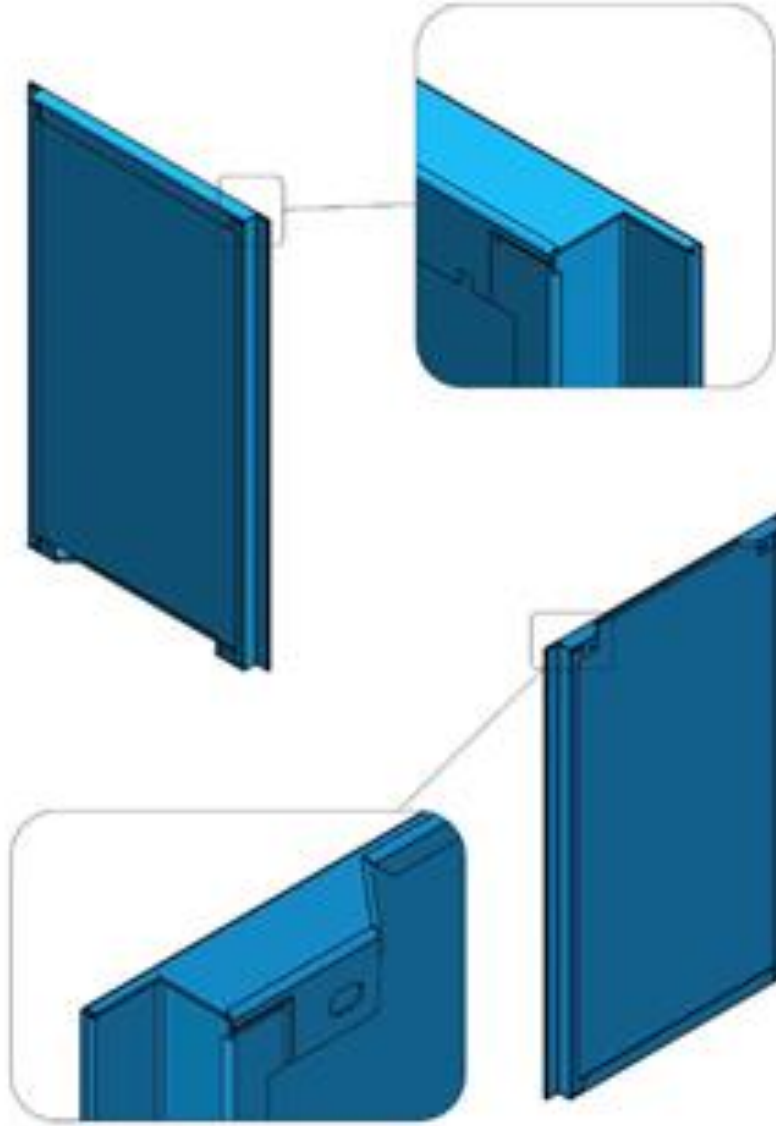

VIESSMANN



2 mm

R1

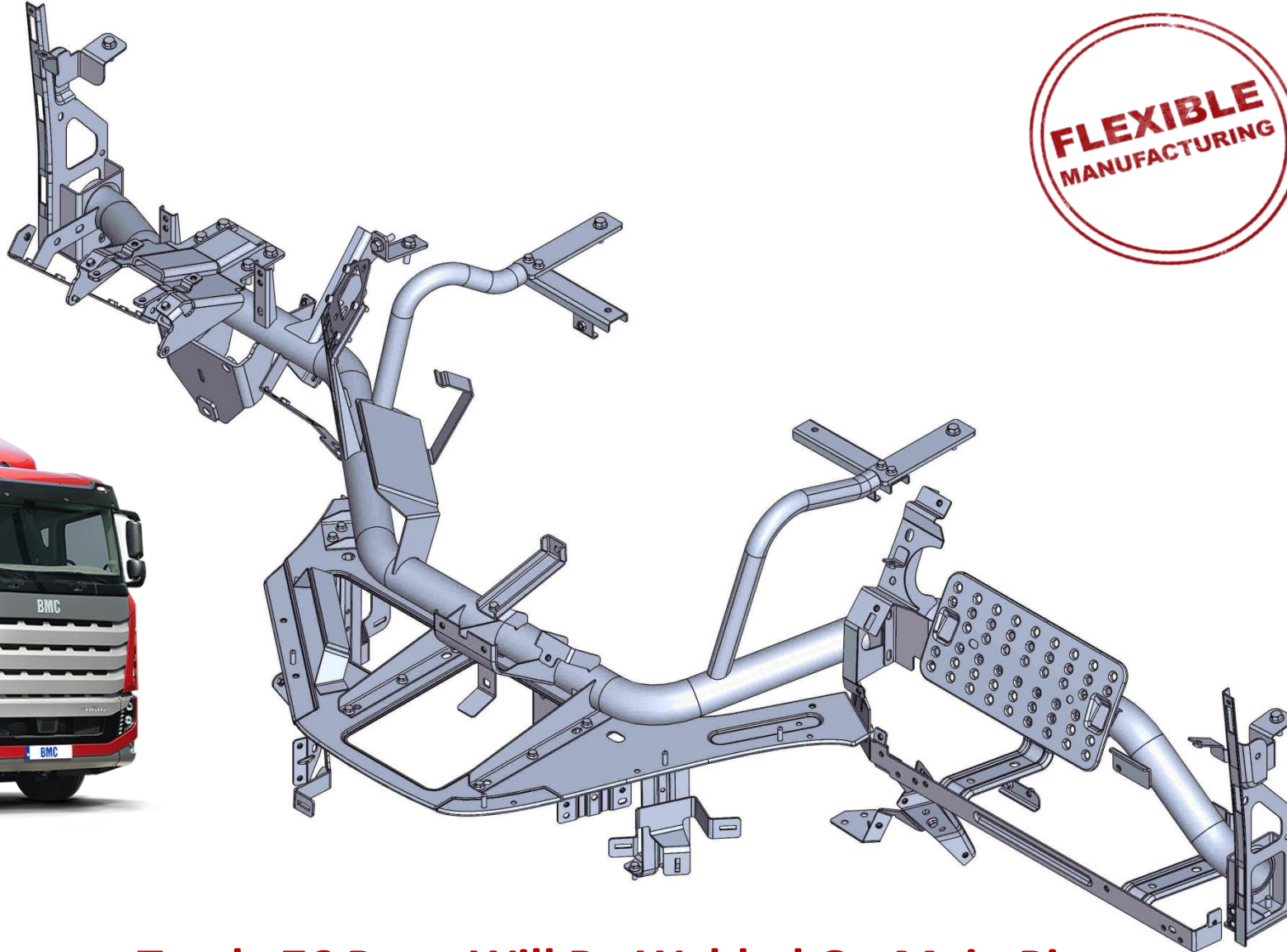

Totaly 76 Parts Will Be Welded On Main Pipe

2160 x 810 x 650 mm

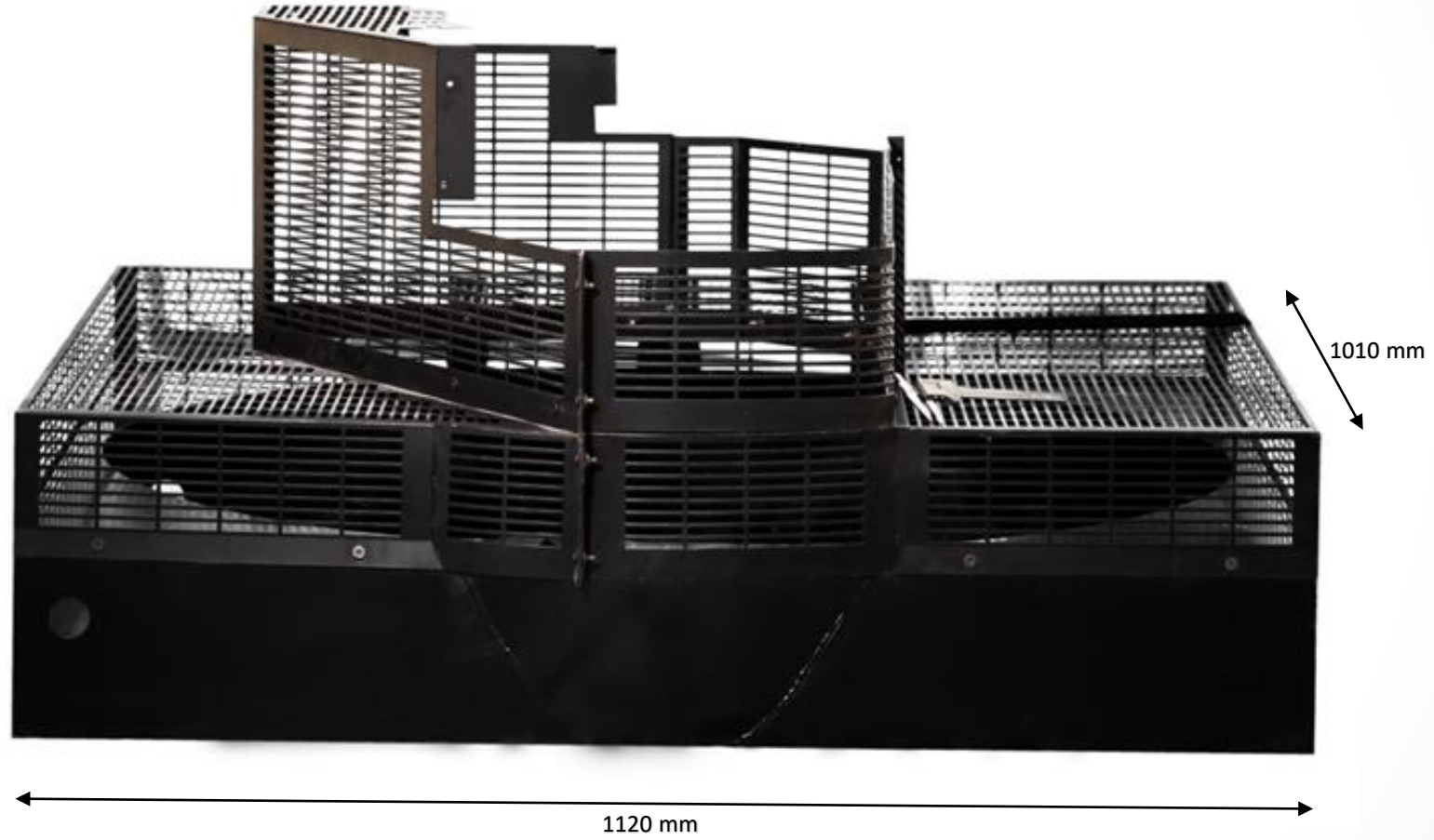

1010 x 1120 x 400 mm



1950 x 2200 x 820 mm

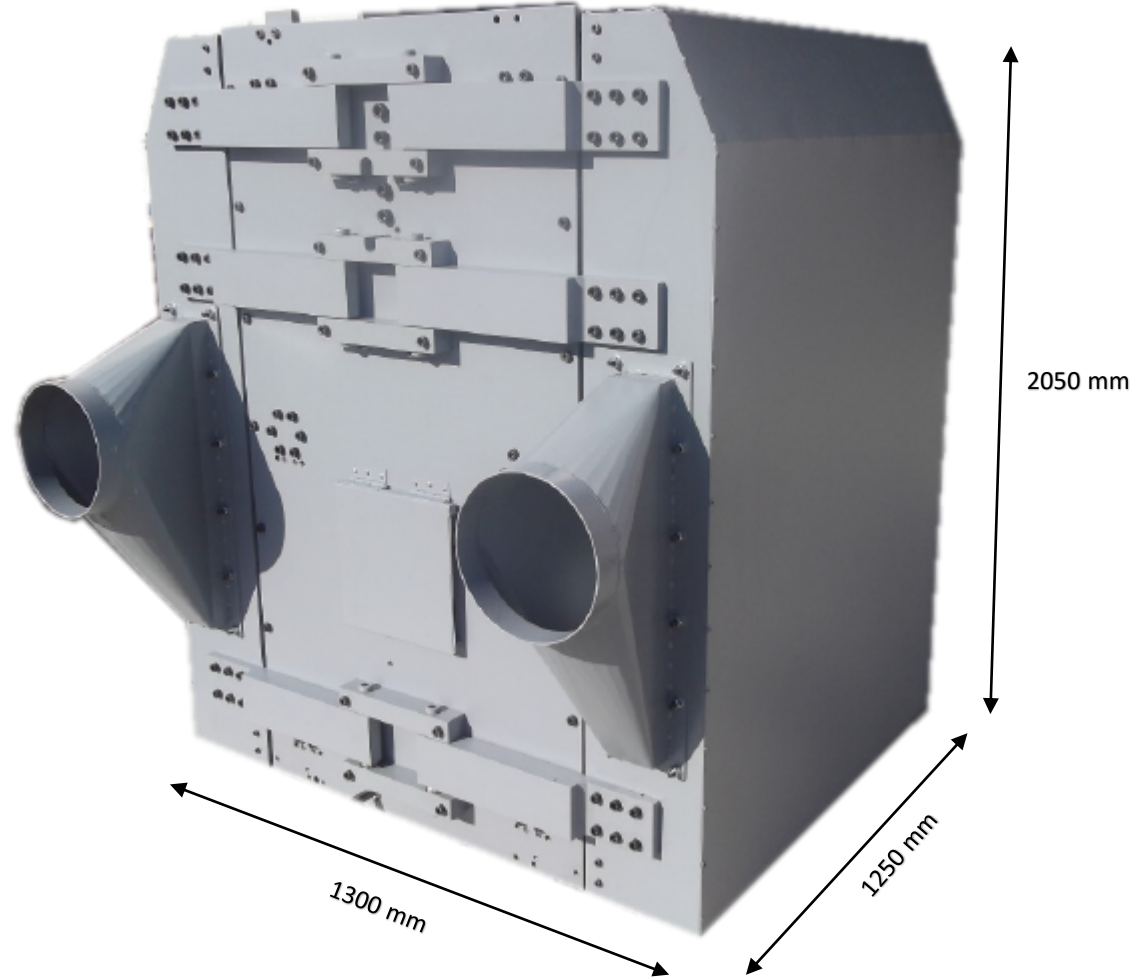

2050 x 1300 x 1250 mm

Deep-Drawing



ebmpapst

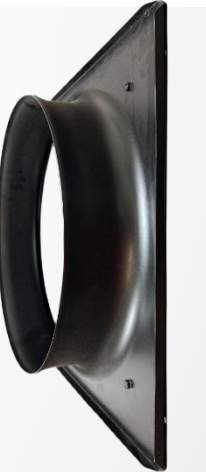

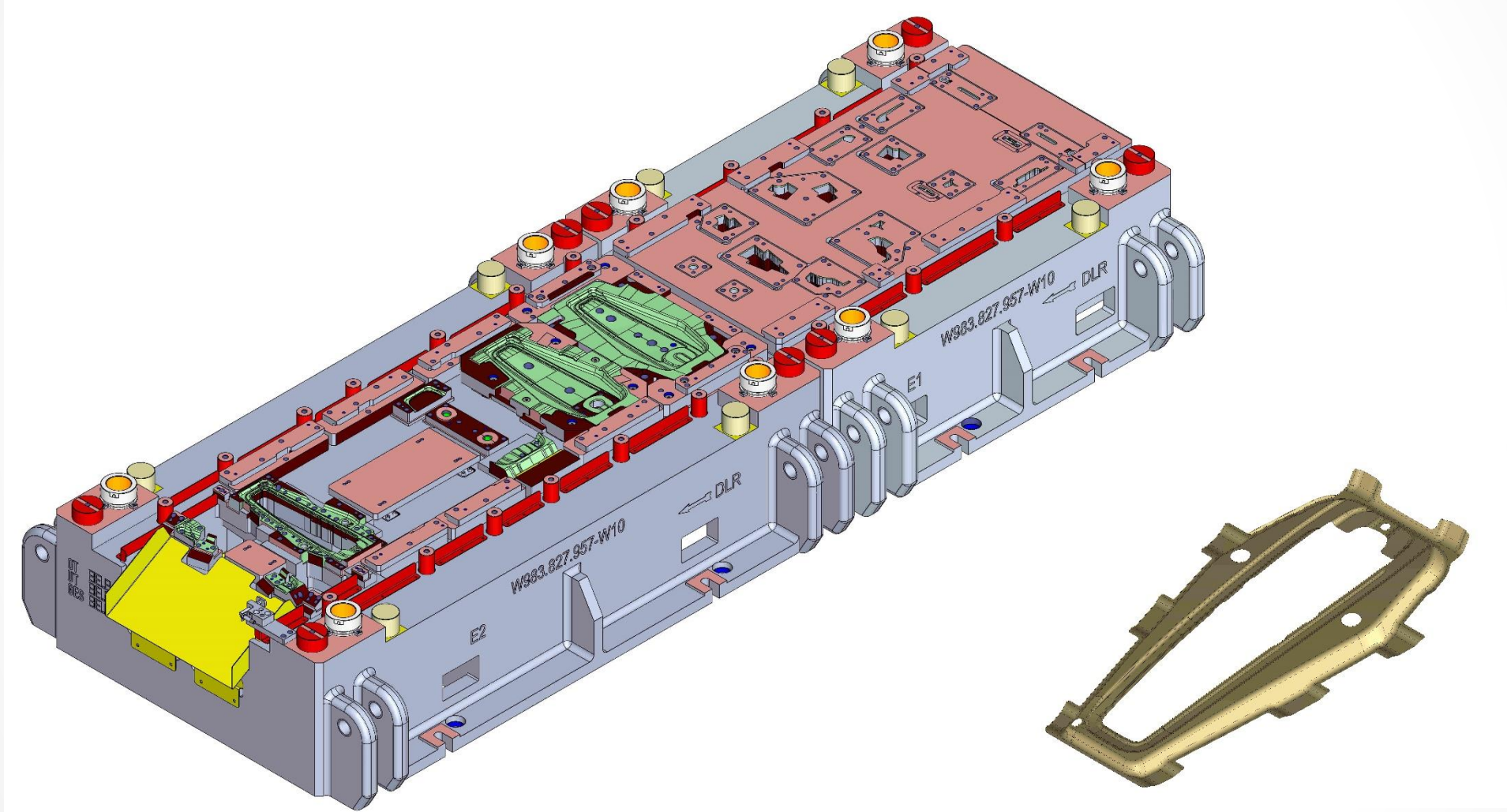

ERXLİBEN
VERFORMUNGSTECHNIK



PORSCHE

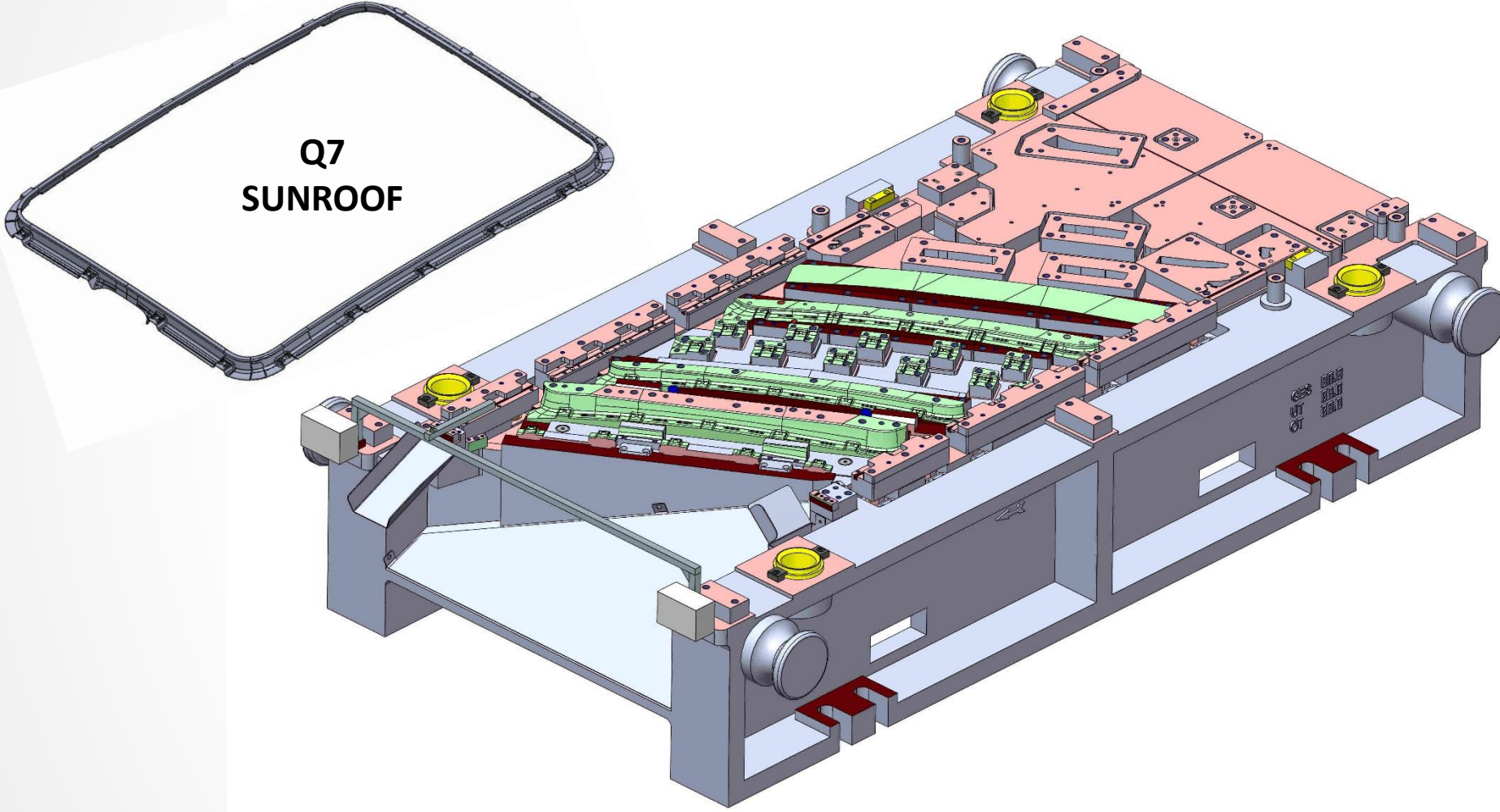

4 Module
8 Die

2700 x 1600 x 1200 mm

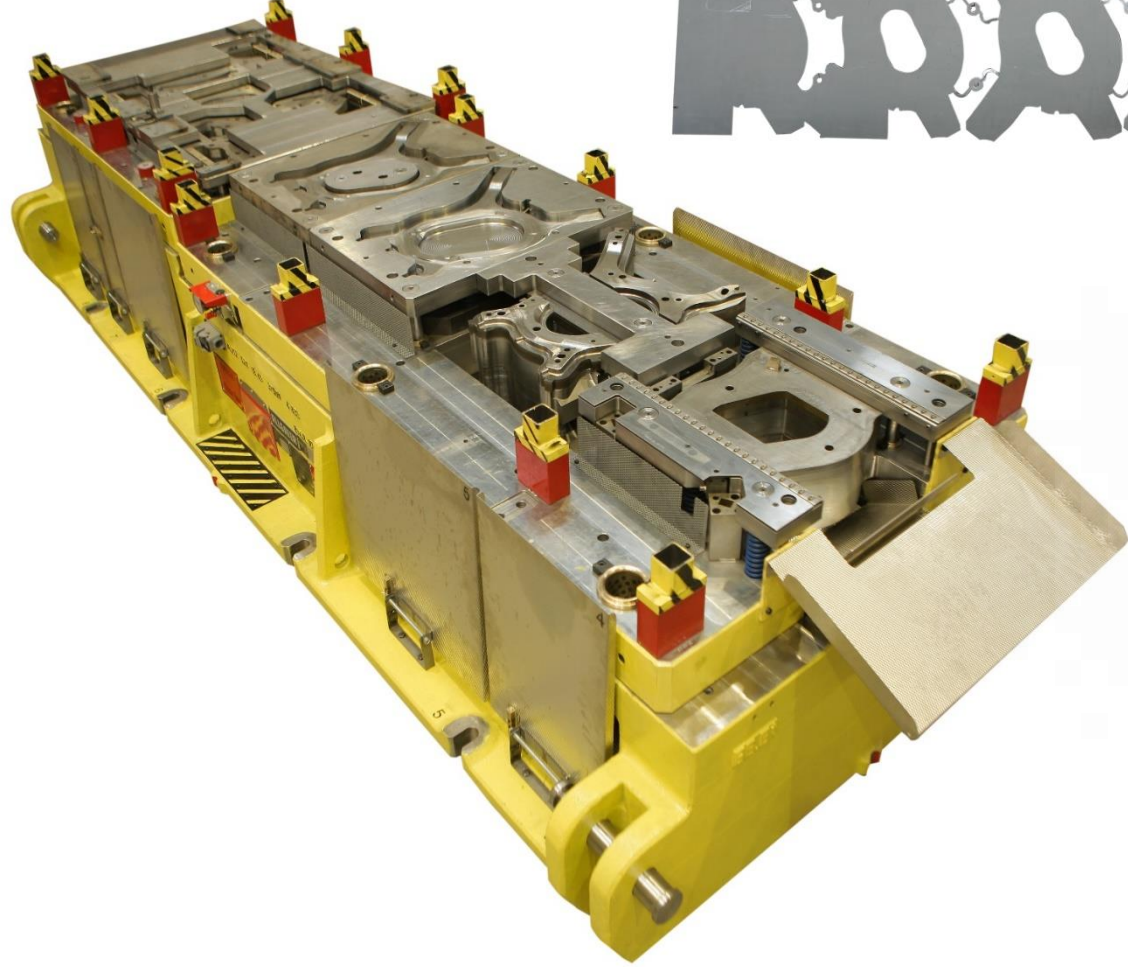

ALLGAIER
Allgaier-Group



Mercedes-Benz



4200 x 1700 x 1150 mm



3 Module

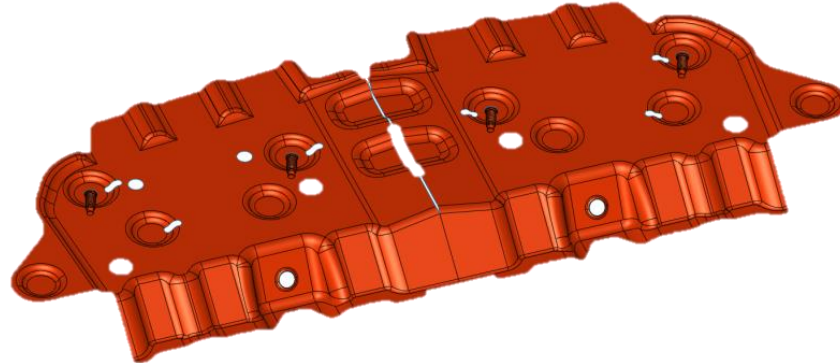

2500 x 1700 x 1100 mm

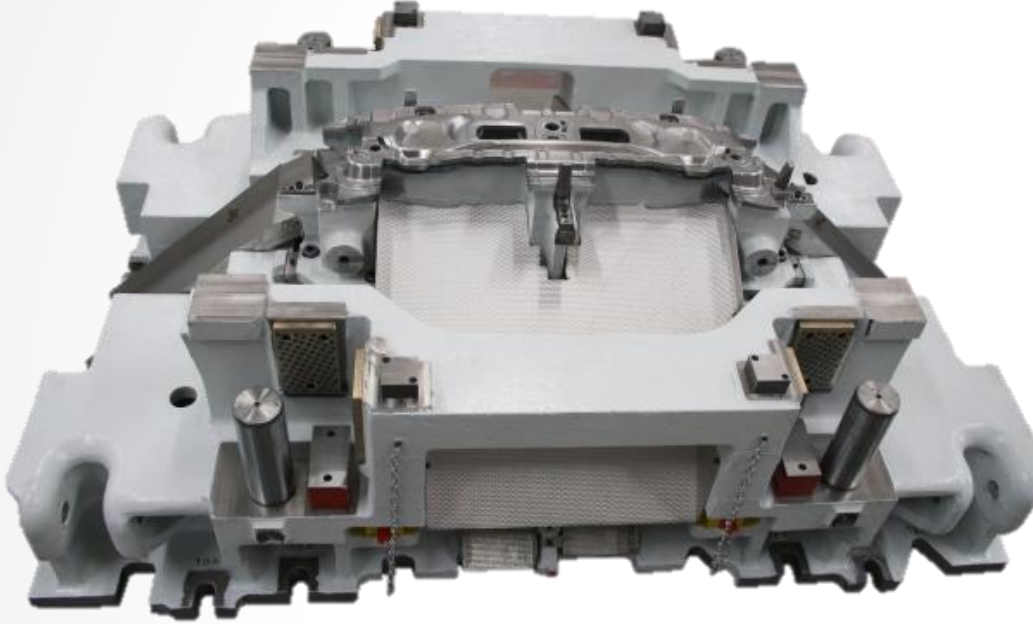

4 Module

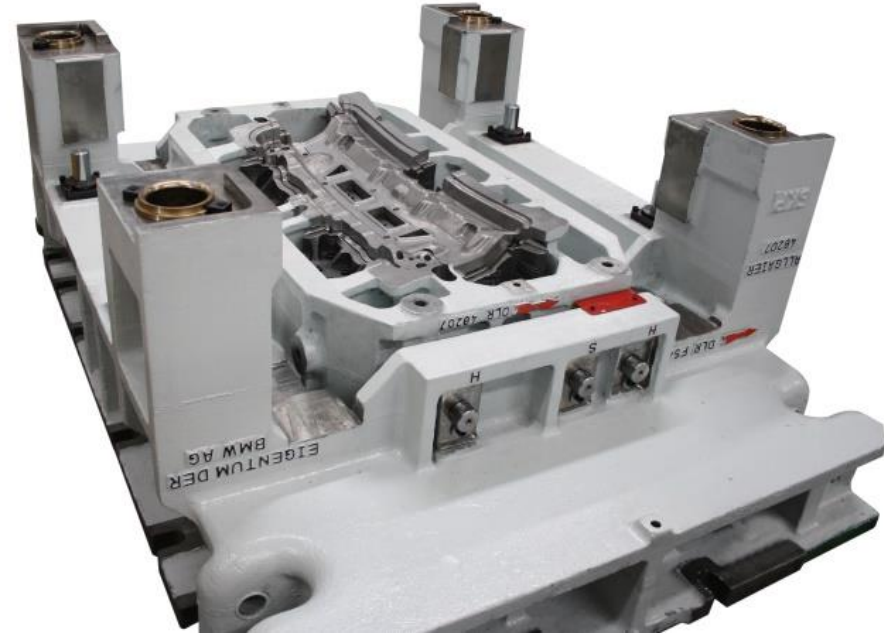
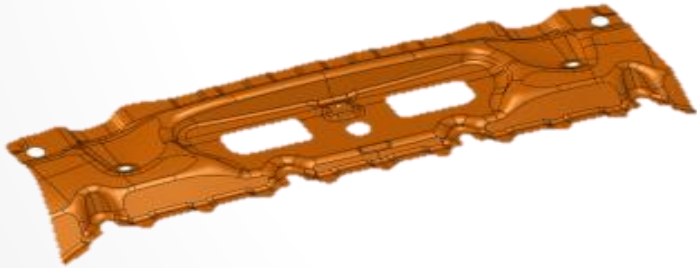

4 Module



Manuel Die 1000 x 800 x 550 mm

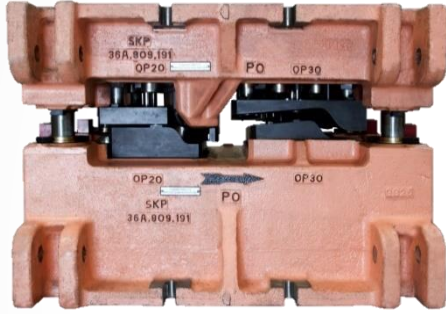

2 Module



Manuel Die 800 x 800 x 550 mm

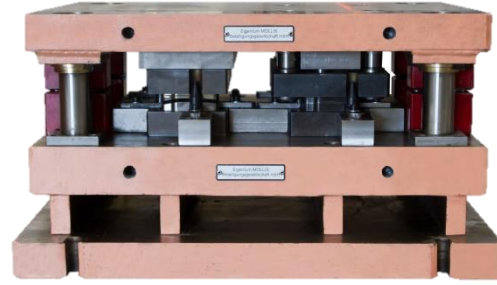

2 Module



Manuel Die 1200 x 800 x 550 mm



2 Module



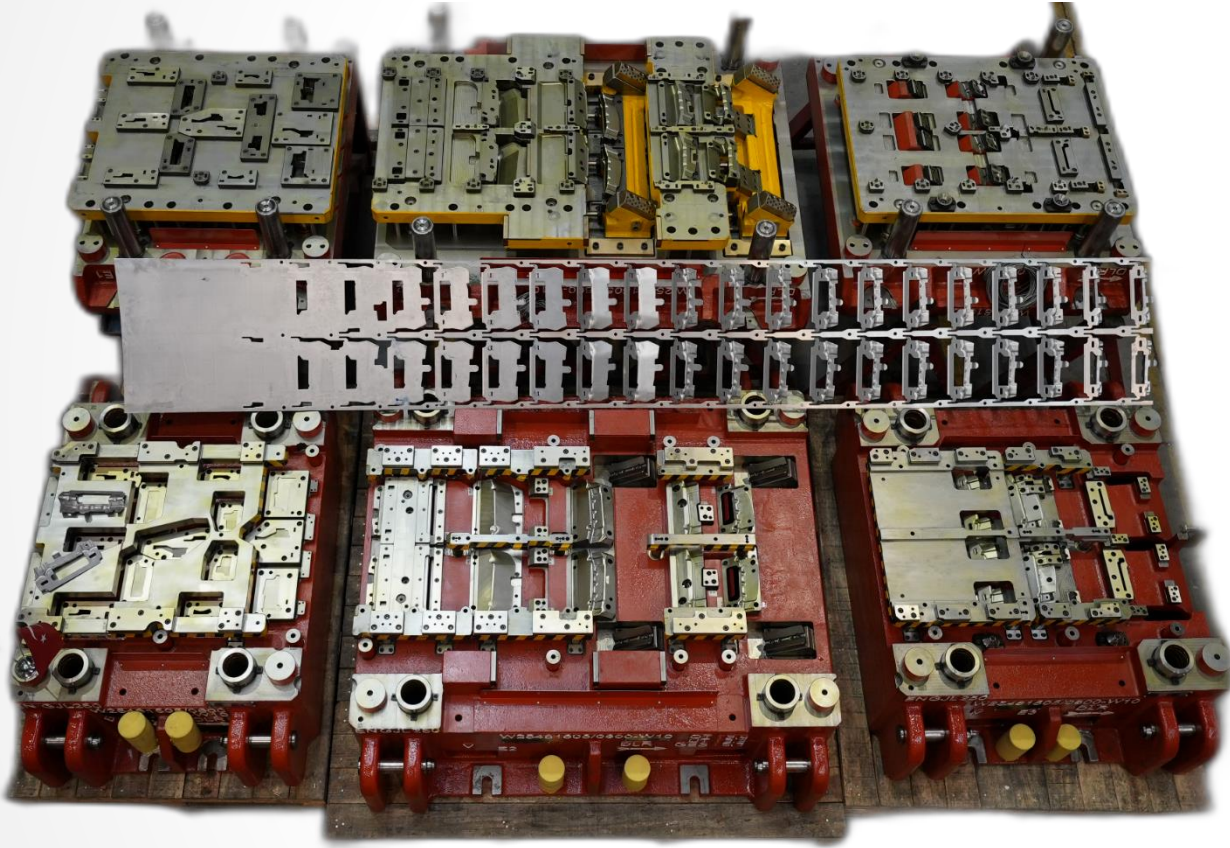

ERXLEBEN
VERFORMUNGSTECHNIK



Mercedes-Benz

4500 x 1600 x 740 mm

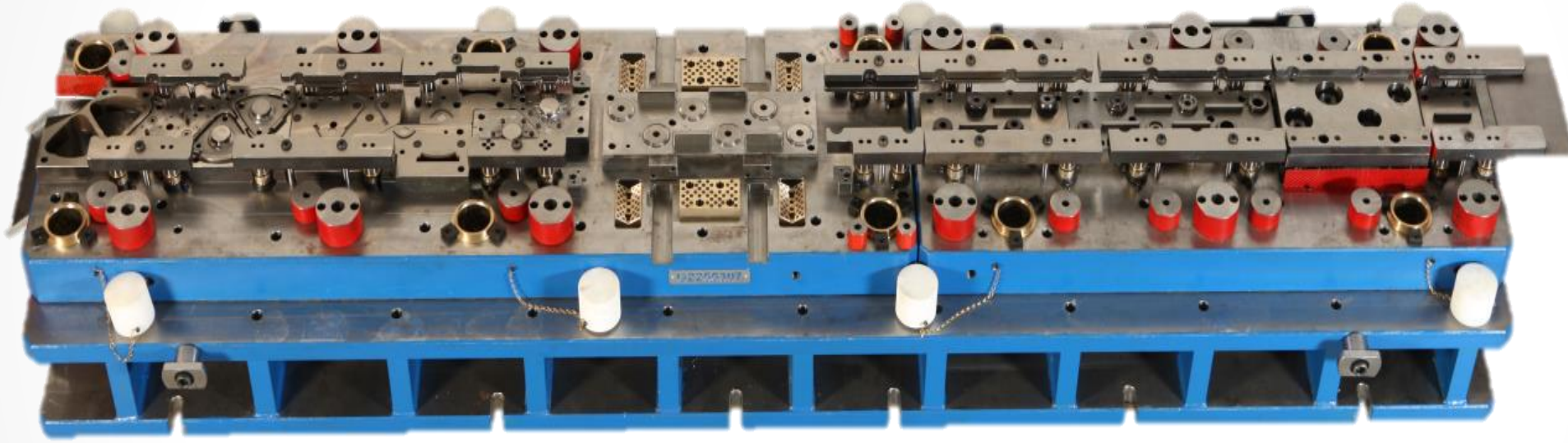

3700x 1000 x 1000 mm

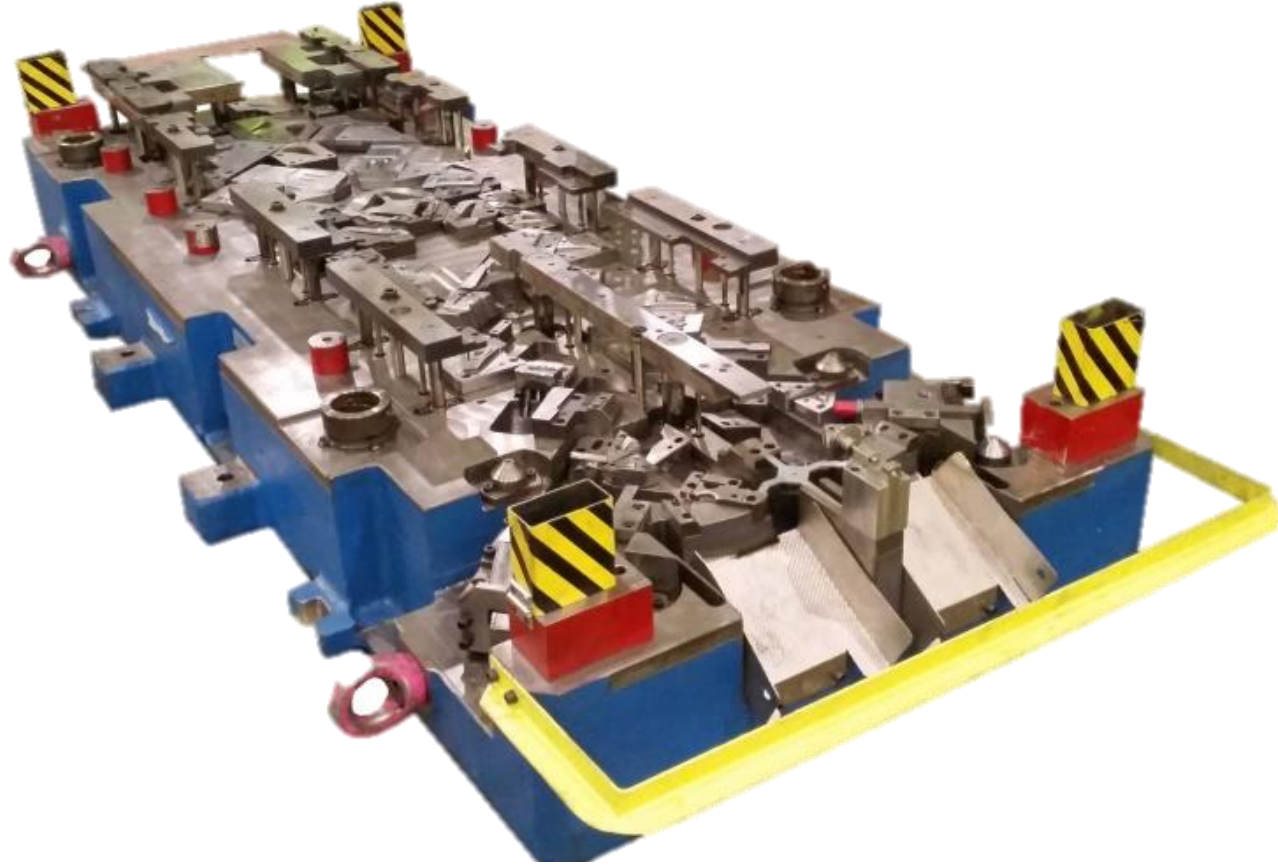

martin
Stanz- und Umformtechnik



2900 x 1140 x 700 mm

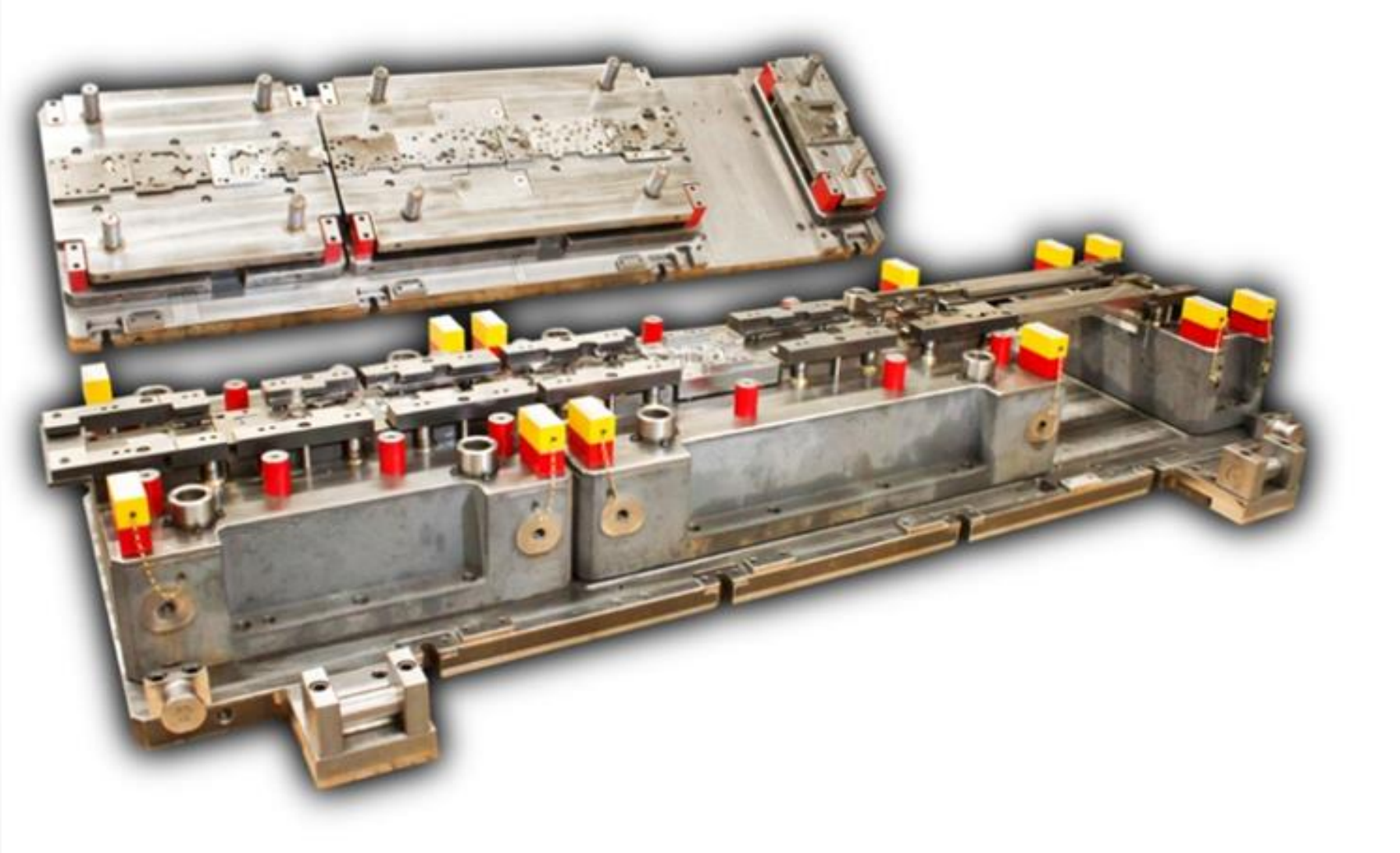

Volkswagen



2800 x 680 x 600 mm

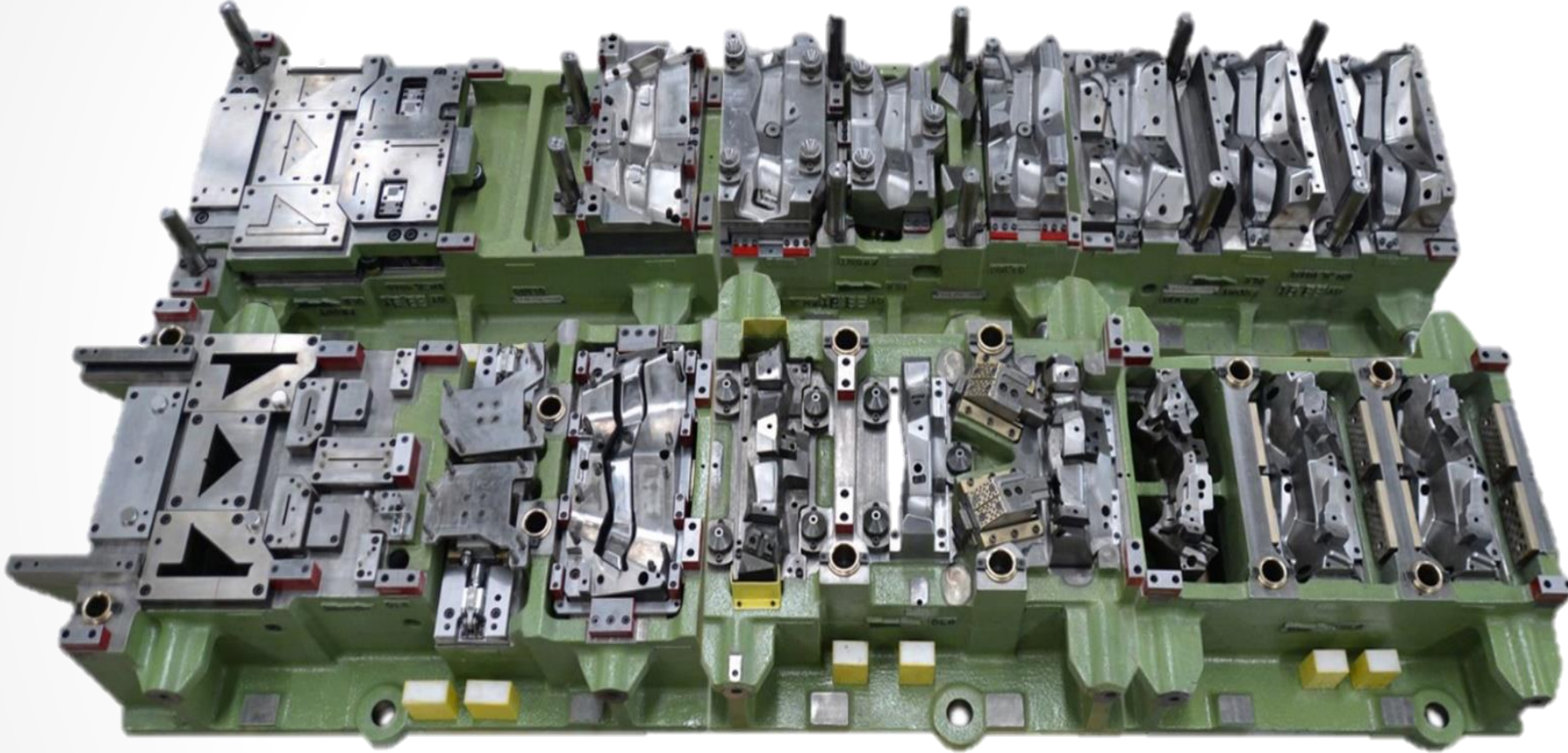

Volkswagen

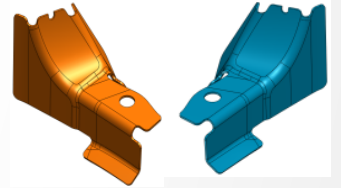

3425 x 940 x 740 mm



Aluminum Plate

ERXLEBEN
VERFORMUNGSTECHNIK



Mercedes-Benz

2800 x 1800 x 1100 mm

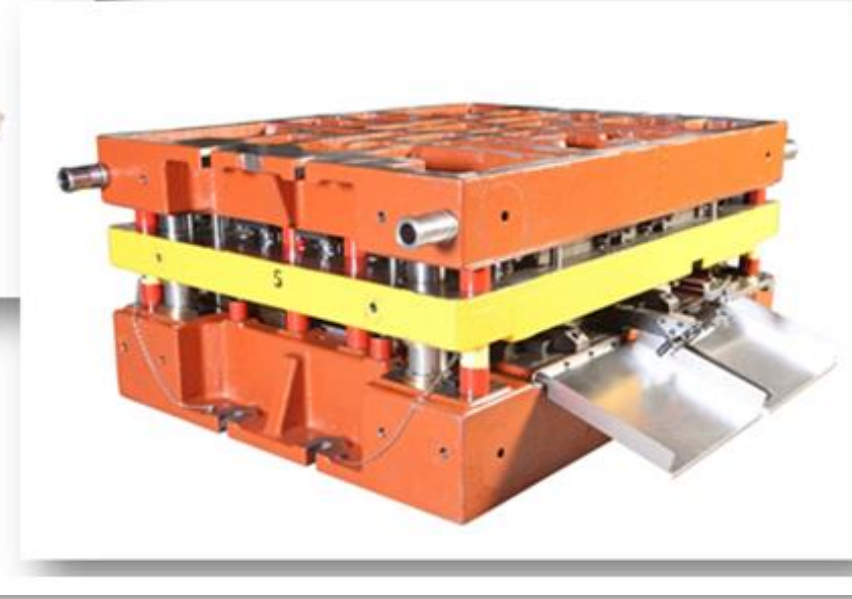

Mercedes-Benz

2100 x 1400 x 600 mm

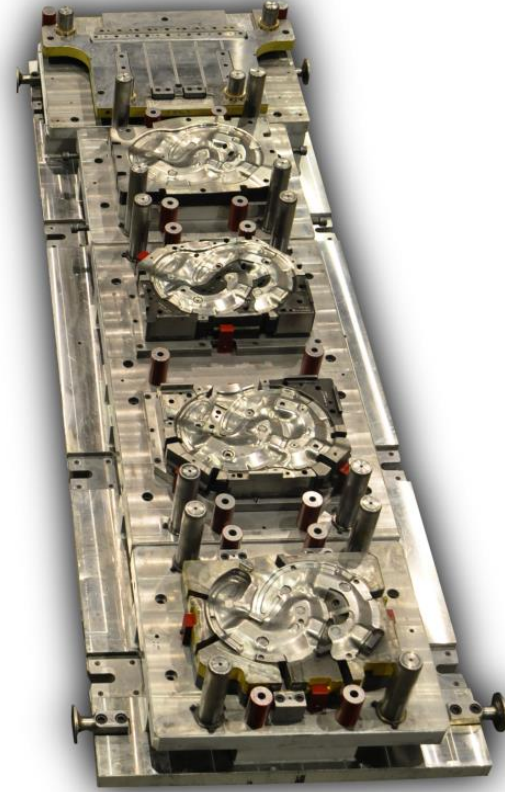
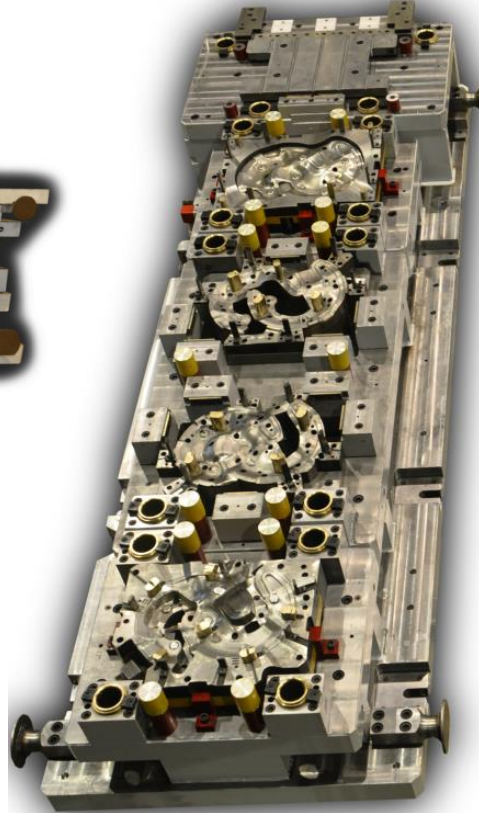
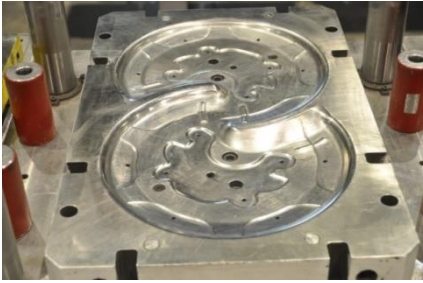

5500 x 1200 x 600 mm

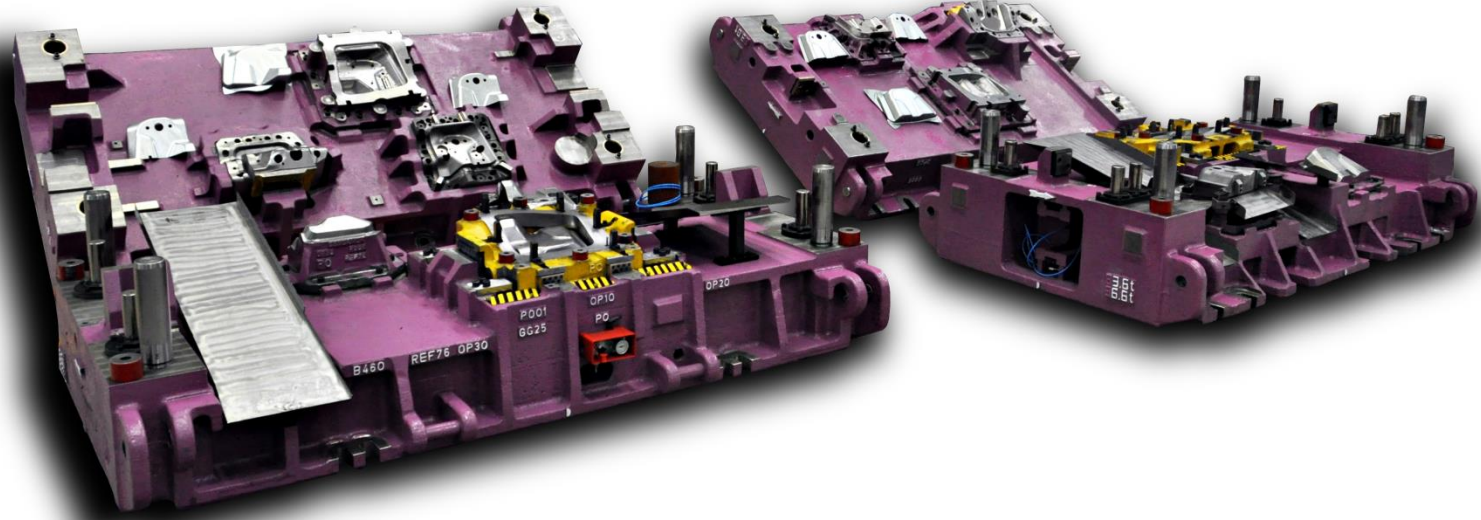

OP10 OP20 OP30

2500 x 1400 x 850 mm

Tandem Dies

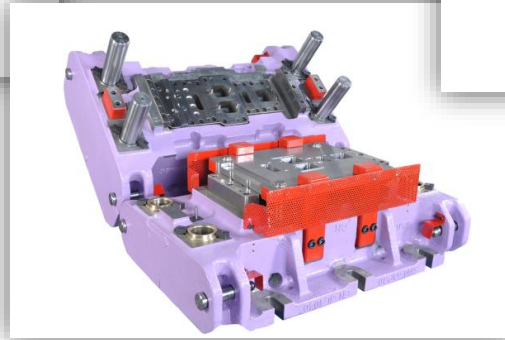

2022 Market Segments

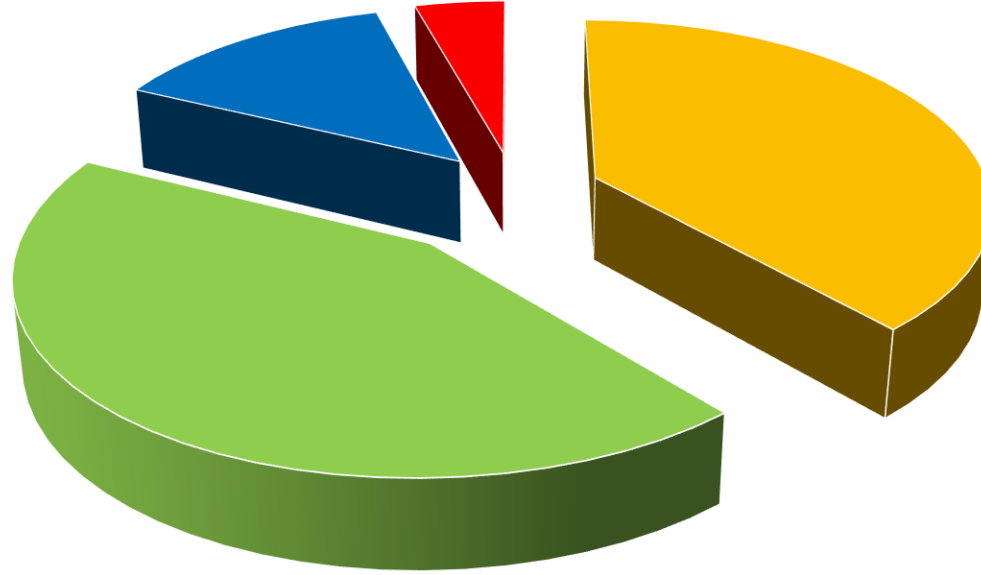

Our services takes us to almost every field imaginable. This chart shows our production range in 2021. Our diverse product range has been developed to meet the needs of our customers and is being continually adjusted to keep pace in the changing marketplace.

Household appliance-Heating %39 **Household appliance-Cooling %44** **Automotive %14** **Others %4**



Fabrika 1

M.O.S.B IV. Kisim Keçilköyosb Mahallesi
Cevdet İnci Caddesi No: 3 PK
45030 Manisa – TÜRKİYE



Fabrika 2

M.O.S.B IV. Kisim Keçilköyosb Mahallesi
Yusuf SARİBEKİR Caddesi No:1
45030 Manisa – TÜRKİYE

